



US006700127B2

(12) **United States Patent**  
**Schneiker et al.**

(10) **Patent No.:** **US 6,700,127 B2**  
(45) **Date of Patent:** **Mar. 2, 2004**

(54) **POINT SOURCE FOR PRODUCING ELECTRONS BEAMS**

(75) Inventors: **Conrad W. Schneiker**, Austin, TX (US); **Stuart Hameroff**, Tucson, AZ (US); **Robert W. Gray**, Rochester, NY (US)

(73) Assignee: **Biomed Solutions LLC**, West Henrietta, NY (US)

(\*) Notice: Subject to any disclaimer, the term of this patent is extended or adjusted under 35 U.S.C. 154(b) by 12 days.

(21) Appl. No.: **10/042,795**

(22) Filed: **Jan. 9, 2002**

(65) **Prior Publication Data**

US 2003/0127594 A1 Jul. 10, 2003

(51) **Int. Cl.<sup>7</sup>** ..... **H01J 37/073**

(52) **U.S. Cl.** ..... **250/423 F; 250/442.11**

(58) **Field of Search** ..... **250/423 F**

(56) **References Cited**

U.S. PATENT DOCUMENTS

5,587,586 A \* 12/1996 Kruit ..... 250/423 F

\* cited by examiner

*Primary Examiner*—John R. Lee

*Assistant Examiner*—James J Leybourne

(74) *Attorney, Agent, or Firm*—John M. Hammond; Howard J. Greenwald

(57) **ABSTRACT**

An apparatus for producing an electron beam, containing a vacuum chamber, a source of electron beams within the vacuum chamber, and a device for focusing the electrons beams. An electron transparent window is formed at the end of the vacuum chamber; and the vacuum chamber has a volume of less than about 1 cubic millimeter and a pressure of less than  $10^{-7}$  Torr. In one embodiment, the focusing device is located outside of the vacuum chamber.

**33 Claims, 9 Drawing Sheets**

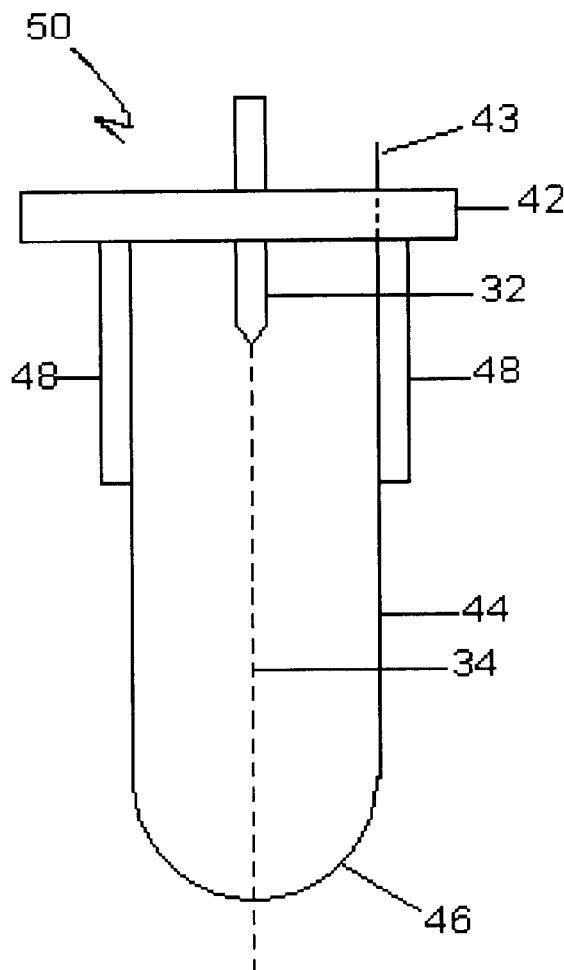

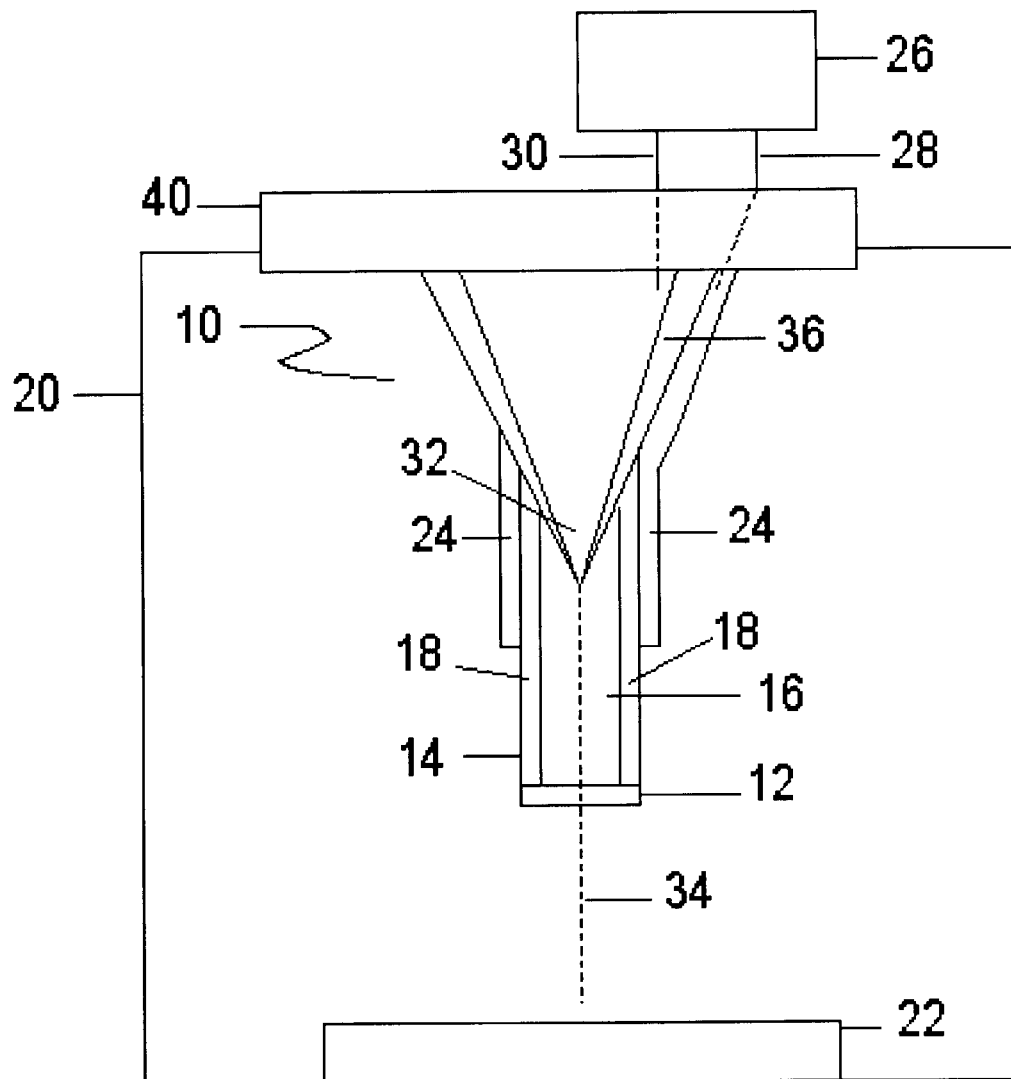

Figure 1

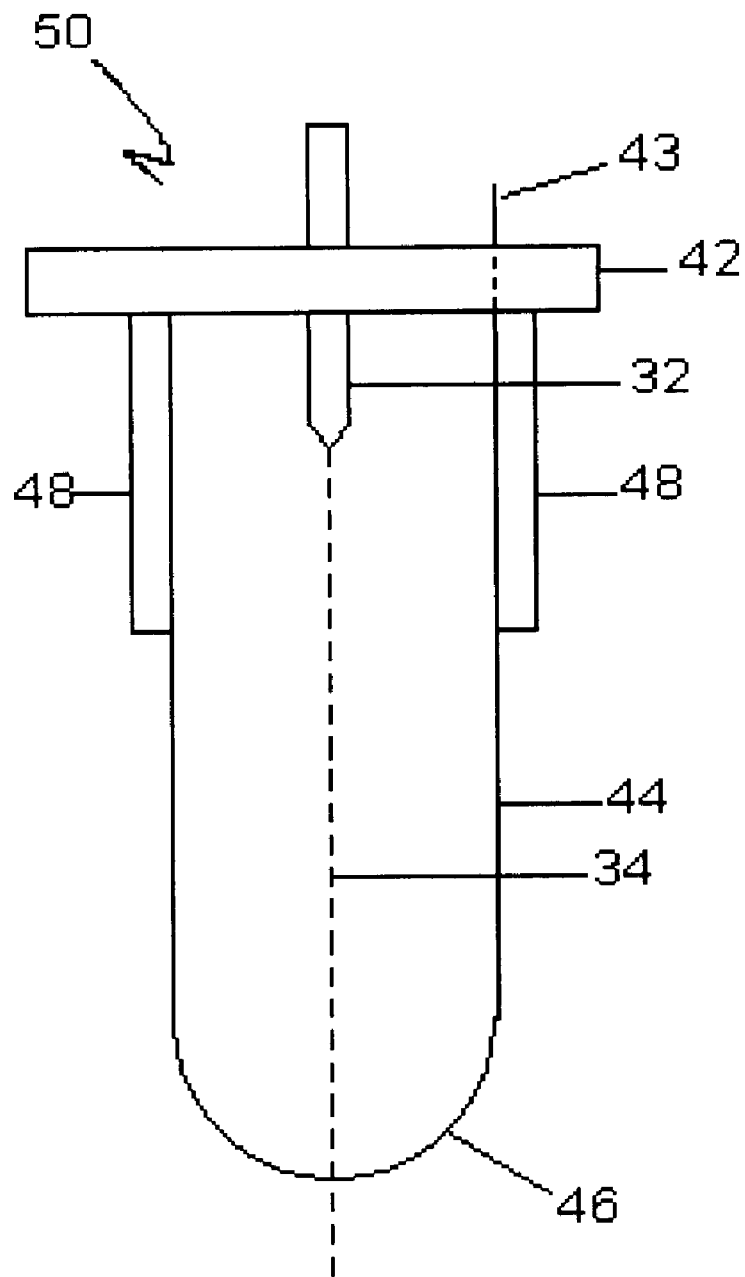

Figure 2

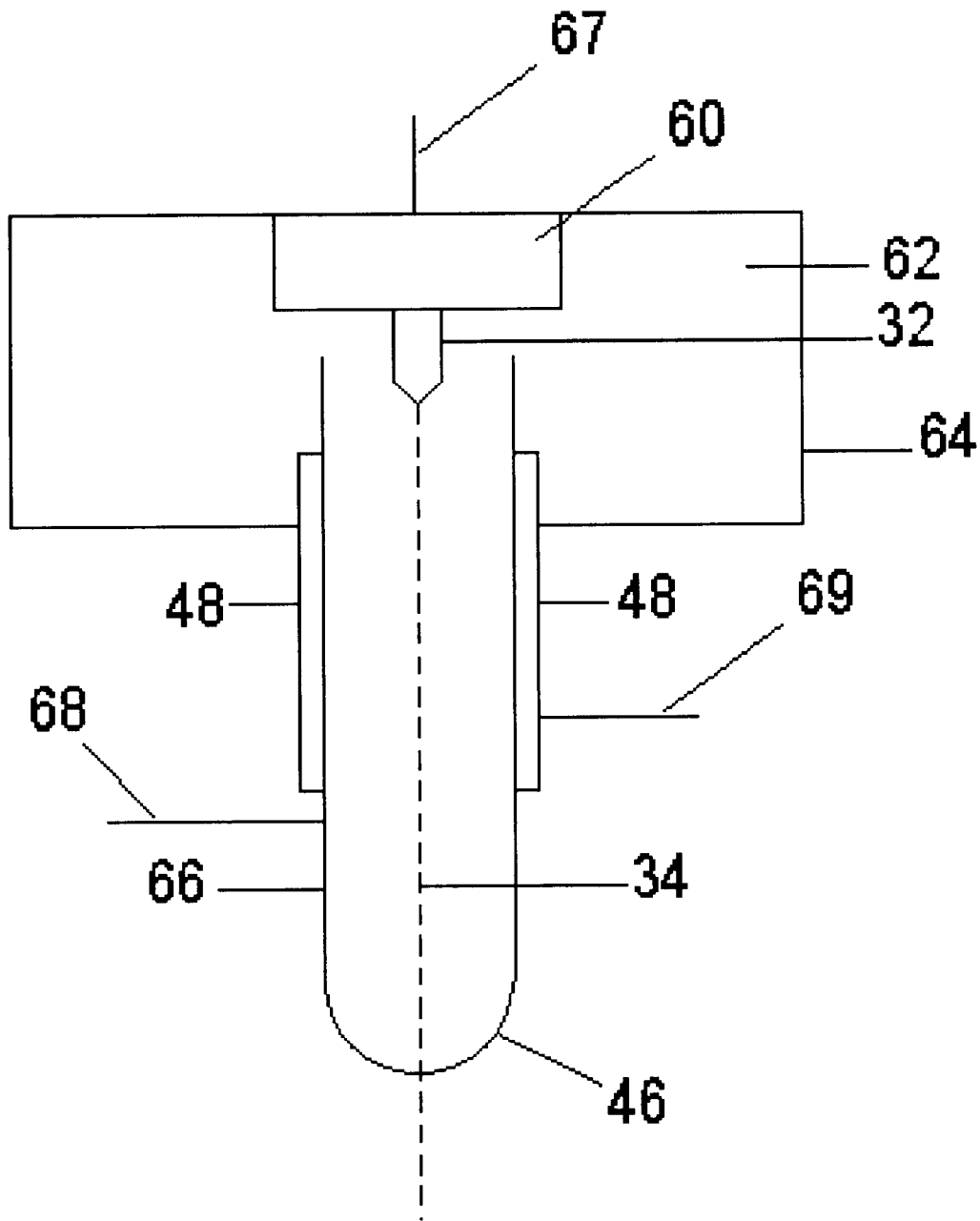

Figure 3

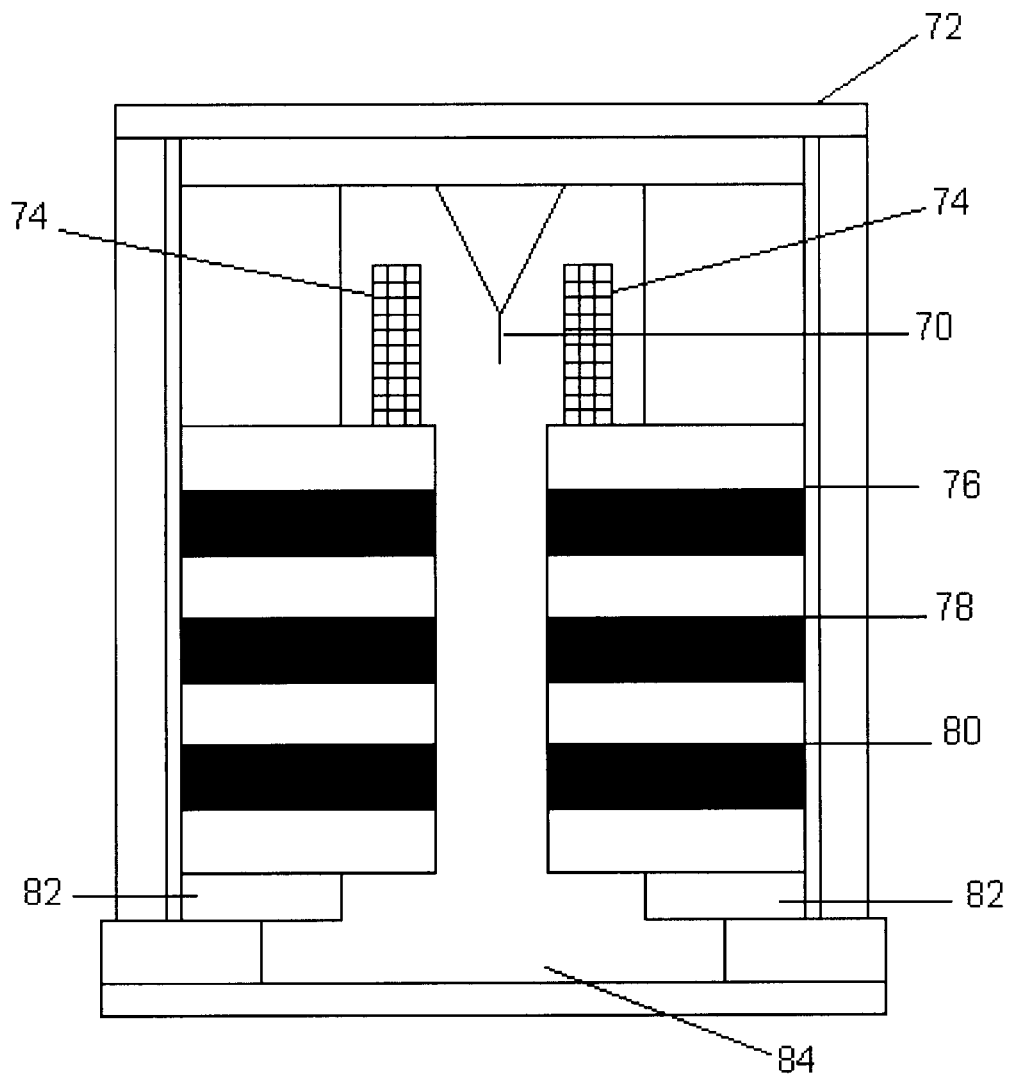

Figure 4

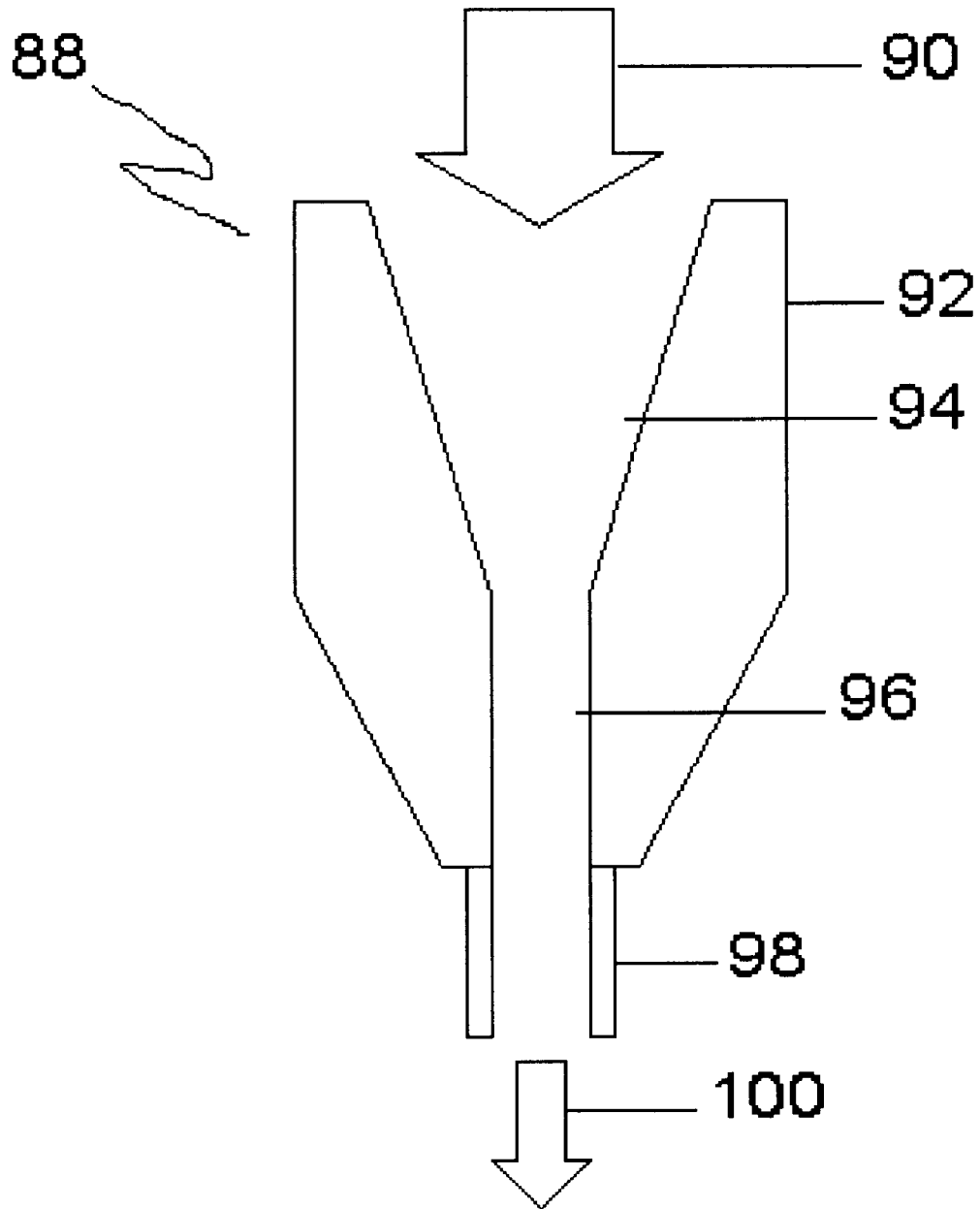

Figure 5

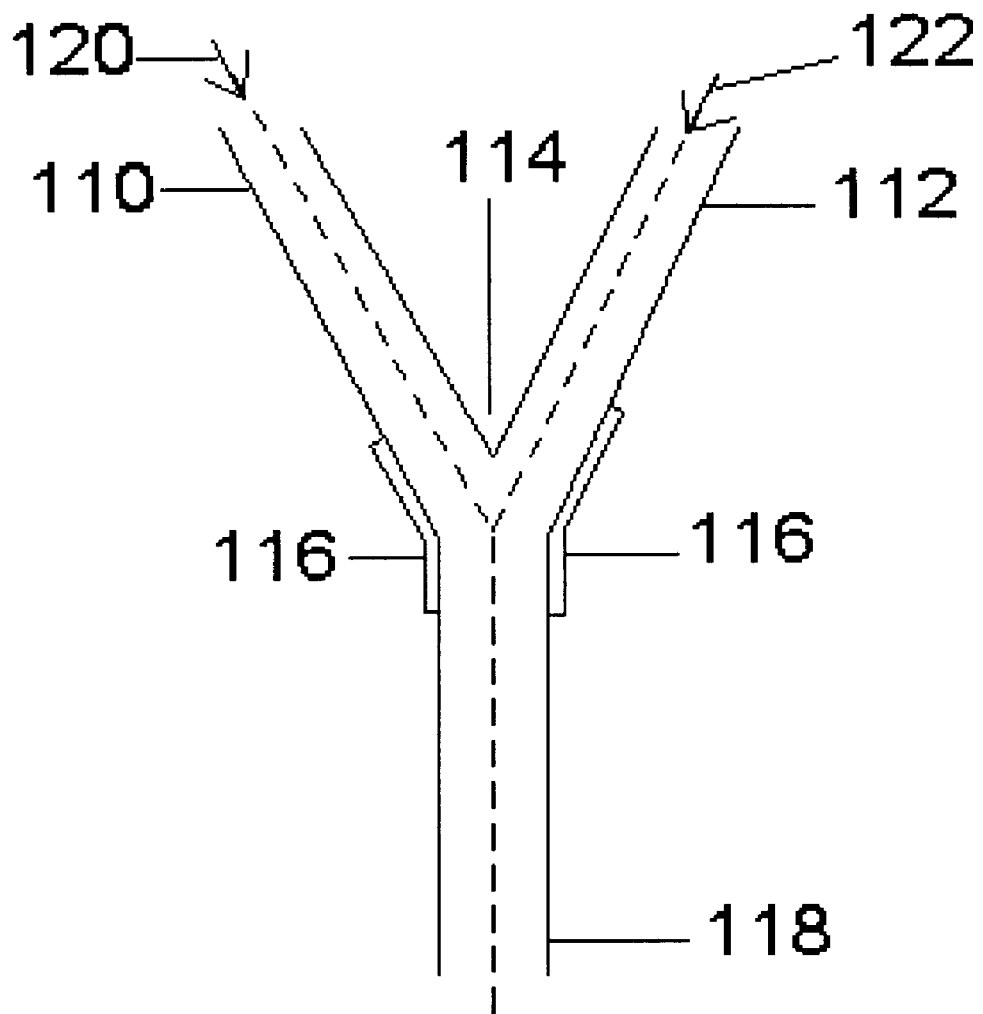

Figure 6

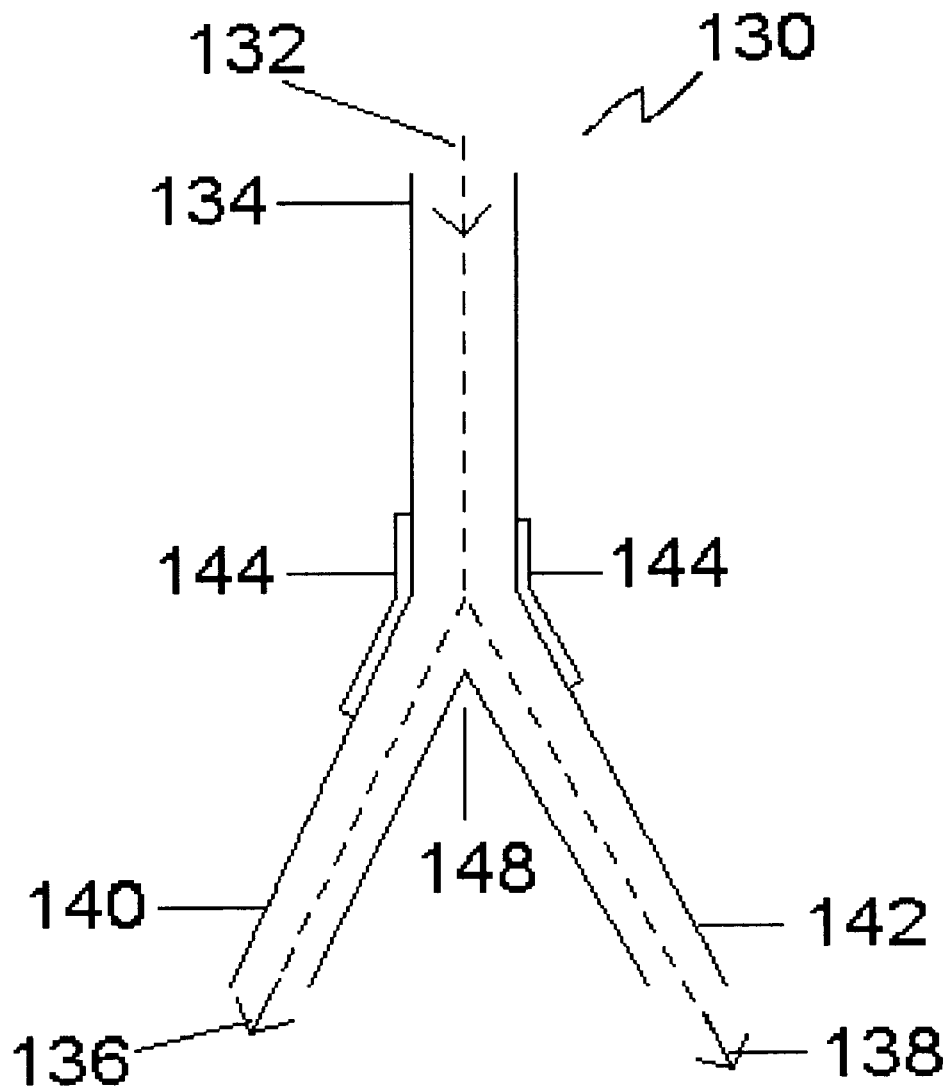

Figure 7



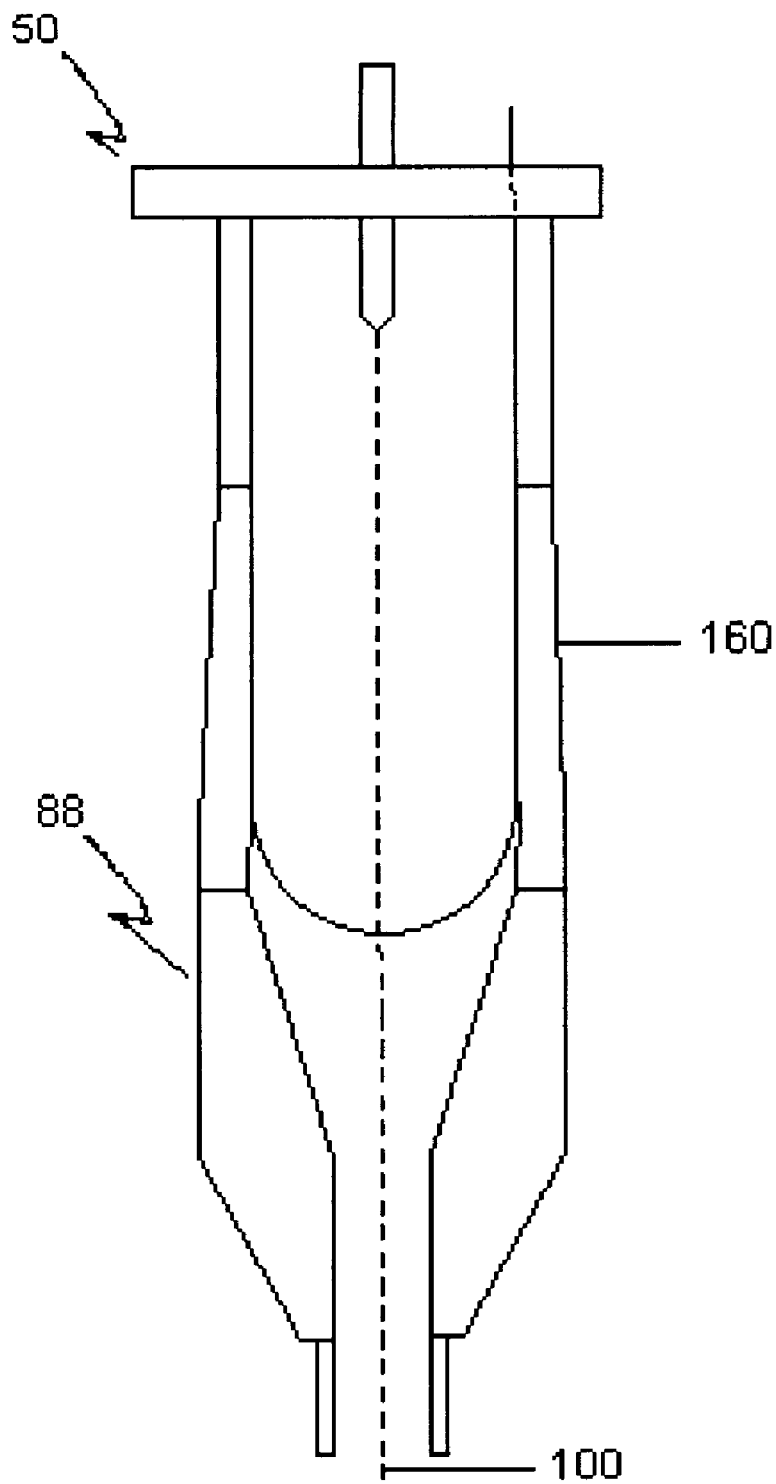

Figure 8

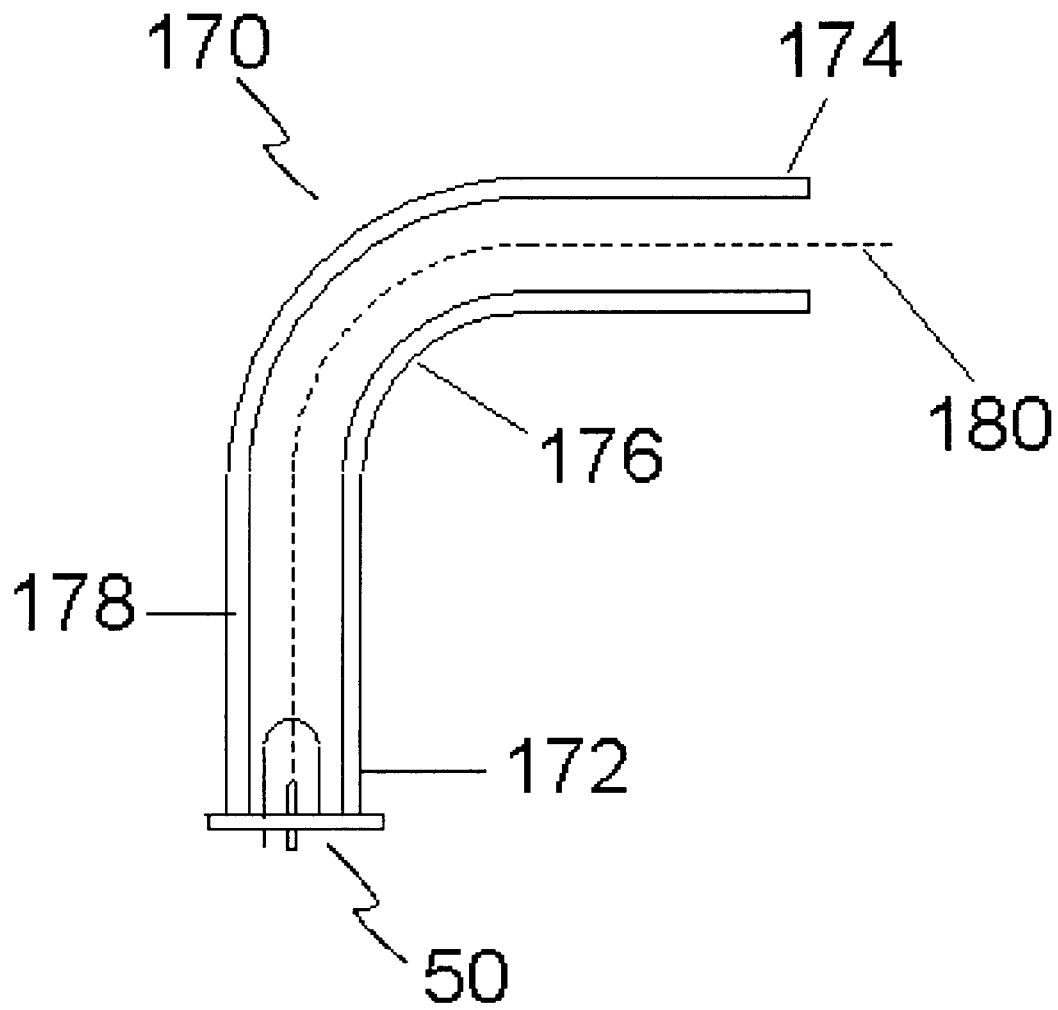

Figure 9

## POINT SOURCE FOR PRODUCING ELECTRONS BEAMS

### FIELD OF THE INVENTION

An apparatus for producing mono-atomic point source electron beams comprises a tip disposed within a first vacuum chamber with a volume of less than about 1 cubic millimeter and a pressure of less than  $10^{-8}$  Torr and an electrode.

### BACKGROUND OF THE INVENTION

Many analytical devices, such as electron microscopes, utilize a focused beam of electrons to illuminate a substrate. Sources of these electron beams are often contained in the tips of the analytical device.

Electron point sources, which may be utilized in these analytical devices, are well known. These electron point sources, often on the order of the atomic scale and adapted to provide field emission of coherent electron beams, have been described in, e.g., "Coherent point source electron beams", Hans-Werner Fink, Werner Stocker, and Heinz Schmid, *Journal of Vacuum Science and Technology B*, Volume 8, Number 6, November/December 1990, pp. 1323-1324, in "Unraveling nanotubes: field emission from an atomic wire," A. G. Rinzler, J. H. Hafner, P. Nikolaev, L. Lou, S. G. Kim, D. Tomanek, P. Nordlander, D. T. Colbert and R. E. Smalley, *Science*, 269, pp. 1550-1553 (1995), and in "Carbon nanotubes are coherent electron sources", Heinz Schmid, Hans-Werner Fink, *Applied Physics Letters*, Volume 70, Number 20, May 19, 1997, pp. 2679-2680. The first reference discloses a tungsten tip terminated with an atomically perfect pyramid of tungsten atoms as the electron emitter. The second and third references disclose a carbon nanotube as the electron emitter.

By way of further illustration, U.S. Pat. No. 5,654,548 ("Source for intense coherent electron pulses") discloses how such sources can be used for one type of electron microscopy. The entire disclosure of this United States patents is hereby incorporated by reference into this specification.

Electron beams have been used in constructing microscopes. For example, U.S. Pat. No. 6,005,247 (Electron beam microscope using electron beam patterns) discloses "An electron beam microscope includes an electron beam pattern source, a vacuum enclosure, electron optics, a detector and a processor." U.S. Pat. No. 6,043,491 (Scanning electron microscope) discloses "A scanning electron microscope in the present invention, by employing a retarding method and suppressing interferences between an electron beam and secondary electrons or back scattered electrons, makes it possible to obtain a clearer SEM image with a higher resolution." The entire disclosure of each of these United States patents is hereby incorporated by reference into this specification.

Field emitted electron beams are also useful in many types of vacuum microelectronic devices, as described in "Vacuum Microelectronics," edited by Wei Zhu, (John Wiley & Sons, New York, 2001).

Fabrication of specialized tips used in scanning electron microscopes and atomic force microscopes is well known to those skilled in the arts. For example, U.S. Pat. No. 6,020,677 (Carbon cone and carbon whisker field emitters) discloses "Carbon cone and carbon whisker field emitters are disclosed. These field emitters find particular usefulness in

field emitter cathodes and display panels utilizing said cathodes." U.S. Pat. No. 5,393,647 (Method of making superhard tips for micro-probe microscopy and field emission) discloses "Forming micro-probe tips for an atomic force microscope, a scanning tunneling microscope, a beam electron emission microscope, or for field emission, by first thinning a tip of a first material, such as silicon." The entire disclosure of each of these United States patents is hereby incorporated by reference into this specification.

The prior art sources of atomic point source electron beam emitters typically must be operated at very low pressures, on the order of about  $10^{-8}$  to  $10^{-10}$  Torr, to protect them from disruptive contamination, chemical degradation, or destructive ion bombardment by residual gas ions. This often requires the use of complicated, expensive, and cumbersome equipment.

It is an object of this invention to provide a device which allows electron beam point sources to be utilized with samples maintained at pressures in a wide range of vacuums from about atmospheric pressure to  $10^{-10}$  Torr. The mechanically protective ultra high vacuum enclosure of these delicate electron beam point sources in conjunction with the exceptionally good electron-optical qualities of such sources makes possible very small source to target distances, ranging from about 1 centimeter to 10 nanometers. This in turn reduces vacuum requirements needed for practical application of such electron beams, including scanning electron microscopy.

### SUMMARY OF THE INVENTION

In accordance with this invention, there is provided an apparatus for providing an electron beam, comprised of a vacuum chamber and comprised of a proximal end and a distal end, wherein the distal end comprises electron transparent material, a source of said electron beam disposed within said chamber, and means for focusing said electron beam from said source of electron beam, wherein said vacuum chamber has a volume of less than about 1 cubic millimeter and wherein the vacuum within said vacuum chamber is greater than  $10^{-7}$  Torr. In one embodiment, an electrode is disposed outside of the vacuum chamber.

### BRIEF DESCRIPTION OF THE DRAWINGS

The invention will be described by reference to the following drawings, in which like numerals refer to like elements, and in which:

FIG. 1 is a schematic of an enclosed point source electron beam generator,

FIG. 2 is a schematic of an enclosed point source electron beam generator,

FIG. 3 is a schematic of an enclosed point source electron beam generator,

FIG. 4 is a schematic of a miniature scanning electron microscope using an enclosed point source electron beam generator,

FIG. 5 is a schematic of an electron beam focusing coupler for a superconducting nano-channel,

FIG. 6 is a schematic of a superconducting nano-channel Y junction and,

FIG. 7 is a schematic of a superconducting nano-channel Y junction and,

FIG. 8 is a schematic of a point source electron beam generator coupled to an electron beam focusing superconducting nano-channel and,

FIG. 9 is a schematic of a point source electron beam generator coupled to a superconducting nano-channel.

#### DESCRIPTION OF THE PREFERRED EMBODIMENTS

Atomic scale point source electron beams have many potential advantages for scanning electron microscopy, including higher resolution at lower voltages in much more compact configurations; these electron beam sources also are advantageously used in vacuum microelectronic devices. The primary disadvantage is the requirement for operation at ultra-high vacuum when used as electron field emitters to avoid damage by ion bombardment. By using a miniature ultra-high vacuum chamber to permanently enclose the field emission part, the vacuum requirements for the rest of a scanning electron microscope can be greatly relaxed, leading to major operational and economic advantages, and a much wider range of practical application of this uniquely advantageous point source of coherent electron beams.

In one embodiment, the invention of this patent application comprises the structure and utilization of a mono-atomic tip in place of conventional field emission sources, providing a far superior initial electron beam in terms of narrow beam divergence and narrow energy spread and greatly reducing the requirements for high beam voltages and expensive electron optical systems needed for very high resolution imaging.

The enclosed point source electron beam generator described in this specification may operate with a miniature ultra-high vacuum enclosure with an electron-transparent window. This enables the rest of the system to be operated under more conventional vacuum conditions. The rest of the system may comprise conventional or, due to the very narrow electron beam sources produced at relatively low voltages, greatly miniaturized versions of conventional scanning electron microscopes, scanning transmission microscopes, point projection Fresnel microscopes, electron beam lithography systems, and vacuum microelectronic devices.

An alternative means of generating very fine electron beams at low voltages (about 50 to 500 volts) from a conventional electron beam and coupling it to a superconducting nano-channel is also disclosed. Such beams can be used for the microscopy systems and vacuum microelectronic devices.

Very fine electron beams from any of the above sources may be guided and/or manipulated by superconducting nano-channels.

As is known to those in the field of electron beam technology, suitably oriented magnetic fields may be used to confine electron beams for some distance once they have been suitably created and formed. The small size of the electron beam source of this invention and the ability to position it close to the ultimate target makes it feasible to wholly immerse the entire source-to-target system in the bore of a powerful magnetic field generating system whose internal magnetic field is oriented parallel to the main electron beam axis. The magnetic field system, depending on system size and performance requirements, may employ permanent magnets or conventional electromagnets or superconducting electromagnets, optionally augmented with magnetic pole pieces, following common practices well known to those in the art. Immersing the entire system in this magnetic field has the net effect of causing electrons that would normally radially diverge from the main beam axis to instead spiral around it. For scanning electron microscopy or

scanning electron beam surface modification applications, either the source or target would need to be mechanically scanned relative to the other. Such scanning may for instance be implemented by any of the lateral electromechanical scanning techniques that are used for scanning tunneling microscopes or atomic force microscopes, following common practices well known to those in the field.

In the remainder of this specification reference will be made to the use of single walled superconducting carbon nanotubes. However, it is to be understood that multi-walled superconducting carbon nanotubes may be utilized as well, as may be any other essentially atomically perfect nanotube structure, which, if not naturally superconducting, may be optionally externally coated with a thin film of superconducting material.

In the preferred embodiment illustrated in FIG. 1, there is illustrated a tip assembly 10 comprised of a high quality electron-transparent thin wall 12 positioned at the distal end 14 of an ultra-high vacuum chamber 16.

The thin wall 12 is electron-transparent, i.e., electron beams may be passed through it without significant dispersion or attenuation, relative to the intended application. Electron transparency is a function of electron energy and the type and thickness of the thin wall material. Using means well known to those skilled in the art, the initial electron beam energy would be set for attaining an acceptable level of electron transparency for a particular thin wall material, and then, if needed, the electron beam energy would subsequently be raised or lowered as appropriate for the intended application.

Electron-transparent thin-walls and structures and materials comprising them are well known to those skilled in the art. Reference may be had, e.g., to U.S. Pat. No. 6,300,631 (Method of thinning an electron transparent thin film membrane on a TEM grid using a focused ion beam), U.S. Pat. No. 6,194,720 (Preparation of transmission electron microscope samples), U.S. Pat. Nos. 6,188,068, 6,140,652, 6,100,639, 6,060,839, 5,986,264, 5,940,678 (electronic transparent samples), U.S. Pat. Nos. 5,633,502, 4,680,467, 3,780,334 (Vacuum tube for generating a wide beam of fast electrons), and the like. The entire disclosure of each of these United States patents is hereby incorporated by reference into this specification.

Referring again to FIG. 1, and in the embodiment depicted, wall 12 is preferably a film that preferably has a thickness of from about 1 to about 50 nanometers. In one preferred embodiment, film 12 consists essentially of silicon nitride, boron nitride, or diamond.

The wall 12, in combination with wall 18, define a chamber 16. The vacuum within chamber 16 is preferably greater than about  $10^{-7}$  Torr. In one aspect of this embodiment, the vacuum within chamber 16 is from about  $10^{-7}$  to about  $10^{-10}$  Torr.

The vacuum within chamber 16 may be created by conventional means. In one embodiment, (not shown) the tip assembly 10 is placed within an ultra high vacuum chamber (not shown) during its manufacturing assembly process and chamber 16 is vacuum sealed to the electron transparent wall 12 thus enclosing an ultra high vacuum within chamber 16.

The chamber 16 has a relatively small volume, of preferably less than about 1 cubic millimeter. In one embodiment, the chamber 16 has a volume of less than about 0.1 cubic millimeters.

Referring again to FIG. 1, it will be seen that the tip assembly 10 is utilized within a sample vacuum chamber 20 whose volume may be at least about 1,000 times as great as

5

the volume of chamber 16. However, the vacuum in chamber 20 may be substantially lower than the vacuum in chamber 16. The pressure in chamber 20 is typically at least about 10 to 1,000 times as great as the pressure within chamber 16.

Referring again to FIG. 1, and in the preferred embodiment depicted therein, the tip assembly 10 is disposed above sample 22 and can be moved, by means described elsewhere in this specification, so that it is closer to or further away from sample 22.

Referring again to FIG. 1, and in the preferred embodiment depicted therein, an extraction electrode assembly 24 is preferably disposed around chamber 16. Electrode assembly 24 is electrically connected to external voltage supply 26 by means of conductors 28 and 30.

In another embodiment, not shown, the extraction electrode assembly 24 is disposed within chamber 16.

In one embodiment, the extraction electrode assembly 24 is electrically charged to an electrical potential typically in the range 50 to 500 volts with respect to the field emission tip 32 (which is the mono-atomic point source of electron beam 34).

In the embodiment depicted in FIG. 1, tip assembly 10 may comprise either a single or multi walled carbon nanotube 32 or a tungsten mono-atomic point emitter (not shown). Reference may be had to U.S. Pat. No. 6,159,742 (Nanometer-scale microscopy probes), U.S. Pat. No. 4,939,363 (Scanning tunneling microscope), and the like. The entire disclosure of each of these United States patents is hereby incorporated by reference into this specification.

The extraction electrode assembly 24 may optionally be fashioned from a superconducting material to take advantage of the Meissner effect for narrowing the emission cone of electrons from the emitter due to the superconducting material's expulsion and thus confinement of the magnetic fields of the emerging electrons. The Meissner effect is the ability of a material in a superconducting state to expel all magnetic fields therefrom (i.e., such a superconductor is perfectly diamagnetic and exhibits a permeability of zero). Reference may be had, e.g., to U.S. Pat. No. 4,975,669 (Magnetic bottle employing Meissner effect). The entire disclosure of this United States patent is hereby incorporated by reference into this specification.

Referring again to FIG. 1, and in the preferred embodiment depicted therein, the emission tip 32 is attached to an electrically insulating tip enclosure 36 to isolate the tip 32 from electrode 24. An electrical connection is made from the voltage source 26 to the electrode 24 by means of conductor 28. An electrical connection is made from the voltage source 26 to the tip 32 by means of conductor 30. The entire assemblage is attached to an electrically insulating supporting mount 40.

In this preferred embodiment, the beam extraction voltage preferably is selected according to the type of ultra thin film material used for the electron window 12, since, as is known to those skilled in the arts, transparency is energy dependent. After passage through the electron window 12, the beam 34 can subsequently be accelerated or decelerated as needed to a target-relative voltage in the range of about 20 to 1,000 volts.

FIG. 2 illustrates another configuration of a tip assembly 50 in which tip 32 is in the shape of a carbon nanotube. In this embodiment, tip 32 has a relatively small diameter, in the range of 0.3 to 10 nanometers. In this embodiment, the carbon nanotube may be composed of single or multi-walled metallic-type carbon nanotube; alternatively, it may be composed of tungsten mono-atomic point emitter or other suitable material.

6

Referring again to FIG. 2, the tip 32 is preferably embedded in a support structure 42, which also serves as a thermal sink and ultra-high vacuum seal to a superconducting single walled metallic-type carbon nanotube 44 of relatively larger diameter (in the range, e.g., of approximately 5 to 200 nanometers), which also serves as a field emission extraction electrode and as a miniature ultra-high vacuum chamber. Electrical lead 43 passes through the support structure 42 to provide a means for creating an electrical potential difference between tip 32 and wall 44. In this embodiment, the electron beam 34 emerges from the field emitter 32 and is confined and focused by the superconducting nanotube 44. Since the momentum of the electrons in beam 34 is largely parallel to the wall 44, relatively little force is required to confine it within wall 44. This beam penetrates and emerges from the semispherical end cap 46. This end cap is less strongly superconducting, or may not be superconducting at all, than the rest of the carbon nanotube 44. Since the momentum of the electron beam 34 is perpendicular to the middle of end cap 46, the middle of end cap 46 serves as an electron window for certain material-dependent electron beam energies. An optional coating of material 48, which may optionally be superconducting, may be used for purposes of vacuum sealing, enhanced mechanical strength, or enhanced superconducting focusing of electron beam 34. In another embodiment (not shown), coating 48 may be connected to the electrical lead 43 and is then used as an electron extraction electrode, instead of nanotube 44.

FIG. 3 illustrates another preferred embodiment of this invention. In this configuration, a fixed or dynamic emitter tip positioning system 60 is enclosed in a miniature ultra high vacuum chamber 62 and support structure 64. The tip 32 preferably has a relatively small diameter, e.g. in the range of approximately 0.3 to 10 nanometers; single walled metallic-type carbon nanotube 32 serves as an atomic point source field emitter of electrons 34. Alternatively, the atomic point source field emitter 32 may be a multi-walled carbon, nanotube or a tungsten mono-atomic point emitter or other suitable material. This electron emitter 32 is embedded in a positioning system 60. The support structure 64 also serves as a thermal sink and ultra-high vacuum seal to a superconducting single walled metallic-type carbon nanotube 66 of relatively larger diameter, e.g. in the range of approximately 5 to 200 nanometers, which serves both as a field emission extraction electrode and as a miniature ultra-high vacuum chamber. The electron beam 34 emerges from the field emitter 32 and is confined and focused by the superconducting nanotube 66. The electron beam 34 penetrates the semispherical end cap 46 and emerges from the end of it. This end cap is less strongly superconducting or may not be superconducting at all. Since the momentum of the electron beam is perpendicular to the end cap 46 it serves as an electron window. An optional coating of material 48, optionally superconducting, may be used for purposes of vacuum sealing, enhanced mechanical strength, or enhanced superconducting focusing of the electron beam. In the embodiment depicted in FIG. 3, electrical leads 67, 68 are connected to a voltage supply (not shown) which provides the electrical potential difference between the tip 32 and the field emission extraction electrode 66. Alternatively, an optional electrical lead 69 may be connected to a voltage supply (not shown) when the optional coating of material 48 is to be utilized as the field emission extraction electrode.

The relatively larger single walled carbon nanotubes in FIGS. 2 and 3 may be quite long compared to their diameter, e.g. on the order of a micron or more; in general, such nanotubes have aspect ratios of at least about 1:10 to 1:1000.

The material properties (such as toughness and springiness of such nanotubes) may be adapted to allow the nanotubes to optionally be subjected to mechanical bending involving various high frequency resonant motion patterns, in the kilohertz through megahertz range, depending on specific geometry for purposes of directing, diverting, modulating, or scanning the emergent electron beam.

There are several forms of carbon nanotubes. In general, the most commonly studied forms of carbon nanotubes have physical properties such that they conduct electricity better than copper, they have a tensile strengths over 100 times that of steel, they become superconductors when cooled to extremely low temperatures, and they are exceptionally tough and resilient when subjected to mechanical bending.

The electron transparent structures illustrated in the Figures can be formed by the carbon nanotube end caps **46** shown in FIGS. **2** and **3**. Alternatively, or additionally, these electron transparent structures may be replaced, in part or in whole, by mechanically attaching some other ultra thin film of suitably electron transparent material to the end of an uncapped carbon nanotube.

The micro-enclosed point source electron beam generators **10** of FIG. **1** and **32** of FIGS. **2** and **3** may be mechanically scanned near the target to be imaged or incorporated into the tip of an atomic force microscope for the purpose of very high resolution electron microscopy and spectroscopy; or such point source electron beam generators **10** of FIG. **1** and **32** of FIGS. **2** and **3** can be incorporated into an electron beam micro-column, such as described in "Fabrication of electron-beam microcolumn aligned by scanning tunneling microscope", Jeong-Young Park, et al, Journal of Vacuum Science and Technology A, Volume 15, Number 3, May/June 1997, 1499-1502.

FIG. **4** illustrates the use of a micro-enclosed point source of electrons **70**, (which may consist of any of the systems shown in FIGS. **1**, **2**, and **3**) to substantially improve on other devices, such as, e.g., the device disclosed in Thomas George's "Miniature Electron Microscopes Without Vacuum Pumps", NASA Technical Brief, Vol. 22, No. 8. (JPL NEW TECHNOLOGY REPORT NPO-20335). A low-to-medium vacuum enclosure **72** contains the whole system; in general, the pressure within enclosure **72** is from about  $10^{-5}$  to  $10^{-6}$  Torr. An optional superconducting cylinder **74** can be used for narrowing the conical emerging electron beam. An optional beam extraction electrode and/or beam acceleration or deceleration electrodes **76** may be used. Electrode pair **78** and electrode **80** are used for scan deflection and focus. Backscattered electron detectors **82** are placed above the observation and manipulation stage **84**. Secondary and backscattered electrons may be detected either by a micro channel plate, or a channeltron, or by other conventional means.

The use of superconducting channels for manipulating electron beams has been described in "High Tc bulk superconductor wigglers", Hidenori Matsuzawa, et al, *Applied Physics Letters*, Volume 59, Number 2, Jul. 8, 1991, 141-142. FIG. **5** shows how a relatively large (in the range of approximately 0.1 to 100 micron diameter) beam of electrons or positive ions **90** may be narrowed into a beam **100** by means of a superconducting channel assembly **88**. Beam **90** passes through superconducting material **92** with a converging funnel channel **94** to a channel **96** of dimensions in the range of approximately 1 to 100 nanometer diameter, and through a connected single walled superconducting carbon nanotube **98**. The superconducting structure **92** may optionally be split in planes perpendicular to the funnel axis

into several mutually insulating segments that are mutually electrified so as to facilitate the attraction of electrons into each successive segment.

FIG. **6** illustrates the use of superconducting carbon nanotubes **110**, **112** in the range of about 0.3 to 100 nanometers in diameter constructed into a Y-junction **114**. Because superconductivity is likely substantially reduced in the junction region itself, this region would normally be externally coated with a thin film of superconducting material **116**. The more general use of high temperature superconductors for such coatings and the coating of all channels removes the requirement that the carbon nanotubes be superconducting or be used at the temperature at which they are superconducting. This system can be used to couple an electron beam **120** with an ion beam **122** or with another source of electrons at a different energy level, from inlets **110**, **112** into the Y-junction **114** and to the single coaxial outlet **118**. One of several means of using such a system is to use the electron beam for target illumination and positioning purposes, and using the ion beam for transient milling or ion deposition purposes.

Alternatively, the Y-junction assembly **130** shown in FIG. **7** can be used to split an electron beam **132** entering inlet **134** into 2 beams **136**, **138** exiting at outlets **140**, **142**. Additional thin film coating **144** of a superconducting material may optionally be employed to enhance the superconducting property at the junction **148**. Such junctions need not be symmetric in branching angles or in terms of nanotube diameters. Multiple such splitting and merging junctions may be combined in practice, and may be structured so as to implement nano-scale electron beam analogs of fluidic technology, including feedback loops. Modulation mechanisms may be provided by external pulsed magnetic fields above the local superconducting shielding level, induction of trapped magnetic fields inside and along the axis of nano-channel loops, locally induced transient thermal excursions above the superconducting threshold temperature, mechanical bending, and the use of electrically insulated superconducting channel segments at differing potentials. These can be used in vacuum electronic device systems that dispense with individual solid state cathodes and individual solid state anodes. Such systems can also be realized without using carbon nanotubes, by exploiting the fabrication techniques that are used for micro-electro-mechanical systems. Such device systems can implement analog and digital types of transducer, signal processing, and computing functions. The highly modulated electron beam output of such systems can be used for subsequently miniaturized electron microscopy implementation, and for corollary use in spatially resolved electrochemistry processes.

FIG. **8** illustrates one preferred use of the electron beam emitter assembly **50** of FIG. **2** together with the superconducting channel assemble **88** of FIG. **5**. A material **160** is used to attach assembly **50** to the assembly **88**. In one embodiment, material **160** is a non-conducting material, e.g. Nylon-6, Nylon-66, Teflon or the like, and electrically isolates assembly **50** from assembly **88**. In another embodiment, material **160** is a superconducting material.

Free standing flexible superconducting nanometer scale tubes and fixed superconducting nanometer scale channels formed on supporting substrates, manufactured by means well known to those skilled in the art of micro-lithography and related micro-fabrication techniques, may be used for conveying coherent electron beams with energies corresponding to wavelengths of a similar order of magnitude (e.g. a few electron volts) and provides a nanometer scale electron beam analog of micron scale fiber optical systems.

FIG. 9 illustrates a preferred embodiment in which an electron beam emitter assembly 50 of FIG. 2 is coupled to superconducting channel 170 for conveyance of a coherent electron beam 180. Referring to FIG. 9, superconducting channel 170 consists of a superconducting material 178 in the form of a tube. At one end 172 of channel 170 is attached the electron beam source 50. The electron beam 180 passes through a 90 degree bend 176 in the channel 170 and exits at the channel end 174.

It is to be understood that the aforementioned description is illustrative only and that changes can be made in the apparatus, in the ingredients and their proportions, and in the sequence of combinations and process steps, as well as in other aspects of the invention discussed herein, without departing from the scope of the invention as defined in the following claims.

We claim:

1. An apparatus for producing an electron beam, comprising a first cylindrical vacuum chamber with a proximal end and a distal end, a source of electron beams disposed within said first cylindrical vacuum chamber, and first means for focusing said electrons beams, wherein:

- (a) said distal end of said first cylindrical vacuum chamber comprises an electron transparent thin wall of material,
- (b) said first cylindrical vacuum chamber has a volume of less than about 1 cubic millimeter,
- (c) the pressure within said first cylindrical vacuum chamber is from about  $10^{-8}$  to about  $10^{-10}$  Torr,
- (d) said first means for focusing said electron beams are disposed outside of said first cylindrical vacuum chamber, and wherein, with the exception of said source of electron beams, no other electrical component is disposed within said first cylindrical vacuum chamber, and
- (e) said first cylindrical vacuum chamber is a carbon nanotube vacuum chamber.

2. The apparatus as recited in claim 1, wherein said carbon nanotube vacuum chamber is a single walled carbon nanotube vacuum chamber.

3. The apparatus as recited in claim 1, wherein said carbon nanotube vacuum chamber is a double walled carbon nanotube vacuum chamber.

4. The apparatus as recited in claim 1, wherein said electron transparent thin wall has a thickness of from about 1 to about 50 nanometers.

5. The apparatus as recited in claim 1, wherein said carbon nanotube material is superconductive.

6. An apparatus for producing an electron beam, comprising a first vacuum chamber with a proximal end and a distal end, a source of electron beams disposed within said first vacuum chamber, and first means for focusing said electrons beams, wherein:

- (a) said first vacuum chamber is comprised of a proximal end and a distal end, wherein said distal end comprises electron transparent material,
- (b) said first vacuum chamber has a volume of less than about 0.1 cubic millimeter,
- (c) the pressure within said first vacuum chamber is from about  $10^{-8}$  to about  $10^{-10}$  Torr,
- (d) said first vacuum chamber is disposed within a second vacuum chamber having a volume that is at least about 1,000 times as large as the volume of said first vacuum chamber,
- (e) said first means for focusing said electron beams is an extraction electrode disposed outside of said first vacuum chamber and within said second vacuum chamber,

(f) said extraction electrode has an electric potential of from about 50 to about 500 volts with respect to said source of electron beams, and

(g) a second means for focusing said electron beams comprised of superconductive material is disposed outside of said first vacuum chamber but within said second vacuum chamber.

7. The apparatus as recited in claim 6, wherein said second means of focusing said electron beams is comprised of a first channel.

8. The apparatus as recited in claim 7, wherein said second means of focusing said electron beams is comprised of a second channel.

9. The apparatus as recited in claim 6, wherein said second means of focusing said electron beams is comprised of a flexible superconductive tube.

10. An apparatus for producing an electron beam, comprising:

- (a) a support structure;
- (b) a miniature ultrahigh vacuum chamber comprising a superconducting single walled metallic-type carbon nanotube comprised of a cylindrical wall, a proximal end disposed upon and sealed to said support structure, and a distal end comprising an electron-transparent structure;
- (c) an electron beam emitting tip comprising a second carbon nanotube embedded in said support structure and disposed within said superconducting single walled metallic-type carbon nanotube; and
- (d) means for creating an electrical potential difference between said electron beam emitting tip and said cylindrical wall of said superconducting carbon nanotube.

11. The apparatus as recited in claim 10, wherein said means for creating an electrical potential difference between said electron beam emitting tip and said cylindrical wall of said superconducting carbon nanotube comprises an electrical lead passing through said support structure to said cylindrical wall of said superconducting carbon nanotube.

12. The apparatus as recited in claim 10, wherein said electron-transparent structure of said distal end of said superconducting single walled metallic-type carbon nanotube comprises a semispherical end cap.

13. The apparatus as recited in claim 10, wherein said second carbon nanotube has a diameter between 0.3 and 10 nanometers.

14. The apparatus as recited in claim 13, wherein said second carbon nanotube is a single walled metallic type carbon nanotube.

15. The apparatus as recited in claim 13, wherein said second carbon nanotube is a multi-walled metallic type carbon nanotube.

16. The apparatus as recited in claim 10, wherein said superconducting single walled metallic-type carbon nanotube has a diameter between 5 and 200 nanometers.

17. The apparatus as recited in claim 16, wherein said superconducting single walled metallic-type carbon nanotube has a diameter between 10 and 200 nanometers and said second carbon nanotube has a diameter between 0.3 and 5 nanometers.

18. The apparatus as recited in claim 10, wherein said superconducting single walled metallic-type carbon nanotube has an aspect ratio of diameter:length of at least about 1:10 to 1:1000.

19. The apparatus as recited in claim 10, further comprising a coating disposed on at least a portion of said cylindrical wall of said superconducting single walled metallic-type carbon nanotube.

11

20. The apparatus as recited in claim 19, further comprising an electrical lead passing through said support structure and connected to said coating.

21. The apparatus as recited in claim 10, wherein said support structure, said miniature ultrahigh vacuum chamber, and said electron beam emitting tip are disposed within a second vacuum chamber.

22. The apparatus as recited in claim 21, wherein a means for focusing said electron beam is disposed outside of said first vacuum chamber but within said second vacuum chamber.

23. The apparatus as recited in claim 22, wherein said means of focusing said electron beam is comprised of superconductive material.

24. The apparatus as recited in claim 23, wherein said means of focusing said electron beam is comprised of a first channel.

25. The apparatus as recited in claim 24, wherein said means of focusing said electron beams is comprised of a second channel.

26. The apparatus as recited in claim 22, wherein said means of focusing said electron beams is comprised of a flexible superconductive tube.

27. An apparatus for producing an electron beam, comprising:

- (a) a support structure;
- (b) a miniature; ultrahigh vacuum chamber
- (c) a positioning system enclosed in said miniature ultrahigh vacuum chamber and said support structure;
- (d) a superconducting single walled metallic-type carbon nanotube comprised of a cylindrical wall, a proximal end disposed upon and sealed to said support structure, and a distal end comprising an electron-transparent structure;

12

(e) an electron beam emitting tip comprising a second carbon nanotube embedded in said positioning system and disposed within said superconducting single walled metallic-type carbon nanotube;

(f) a first electrical lead connected to said electron beam emitting tip;

(g) a second electrical lead connected to said superconducting single walled metallic-type carbon nanotube; and

(h) a voltage supply connected to said first electrical lead and said second electrical lead.

28. The apparatus as recited in claim 27, wherein said electron-transparent structure of said distal end of said superconducting single walled metallic-type carbon nanotube comprises a semispherical end cap.

29. The apparatus as recited in claim 27, wherein said second carbon nanotube has a diameter between 0.3 and 10 nanometers.

30. The apparatus as recited in claim 27, wherein said superconducting single walled metallic-type carbon nanotube has a diameter between 5 and 200 nanometers.

31. The apparatus as recited in claim 30, wherein said superconducting single walled metallic-type carbon nanotube has a diameter between 10 and 200 nanometers and said second carbon nanotube has a diameter between 0.3 and 5 nanometers.

32. The apparatus as recited in claim 27, further comprising a coating disposed on at least a portion of said cylindrical wall of said superconducting single walled metallic-type carbon nanotube.

33. The apparatus as recited in claim 32, further comprising an electrical lead connected to said coating.

\* \* \* \* \*